

Overview of C2D

C2D Solutions Pte Ltd is a holistic knowledge-based engineering solutions provider with a wealth of experience. We are committed to deliver the most optimal solution based on sound engineering principles.

Problem Statement

The inadequate ventilation within a Petrochemical Processing Plant (see Figs. 1) has a serious impact on work place health and safety. Site survey and inspection revealed that the airflow within the building was stagnant and the level of thermal comfort was very poor (see Figs. 2).

Challenge

The poor thermal comfort was due to the inability of hot air to vent out of the building at high level and for fresh air to entrain into the building at low level. The extensive roof and facade skylights also cause extensive heating of the interior through solar radiation. A quick fix solution is to introduce air conditioning, however time and cost implications make this strategy non-viable.

Solution

It was decided to strategically place natural ventilation openings to achieve adequate fresh air entrainment and hot air venting. Several ventilation strategies were proposed and Computational Fluid Dynamics (CFD) simulations were used to analyze and optimize the flow field, solar radiation and thermal stratification within the plant.

Results

Introducing strategically-placed natural ventilation openings greatly improved the airflow and thermal comfort within the plant (see Figs. 3). This contributed to improved staff health and morale and greater productivity.

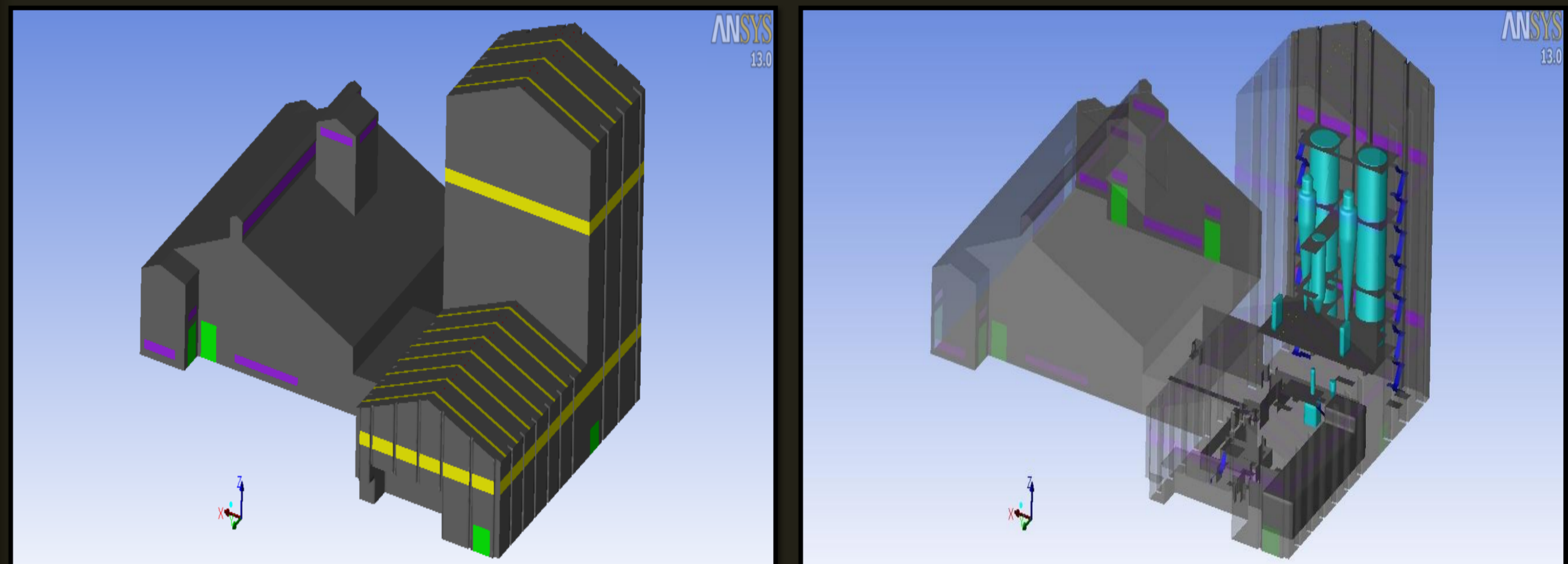

Fig 1: Computational Grid of Petrochemical Processing Plant

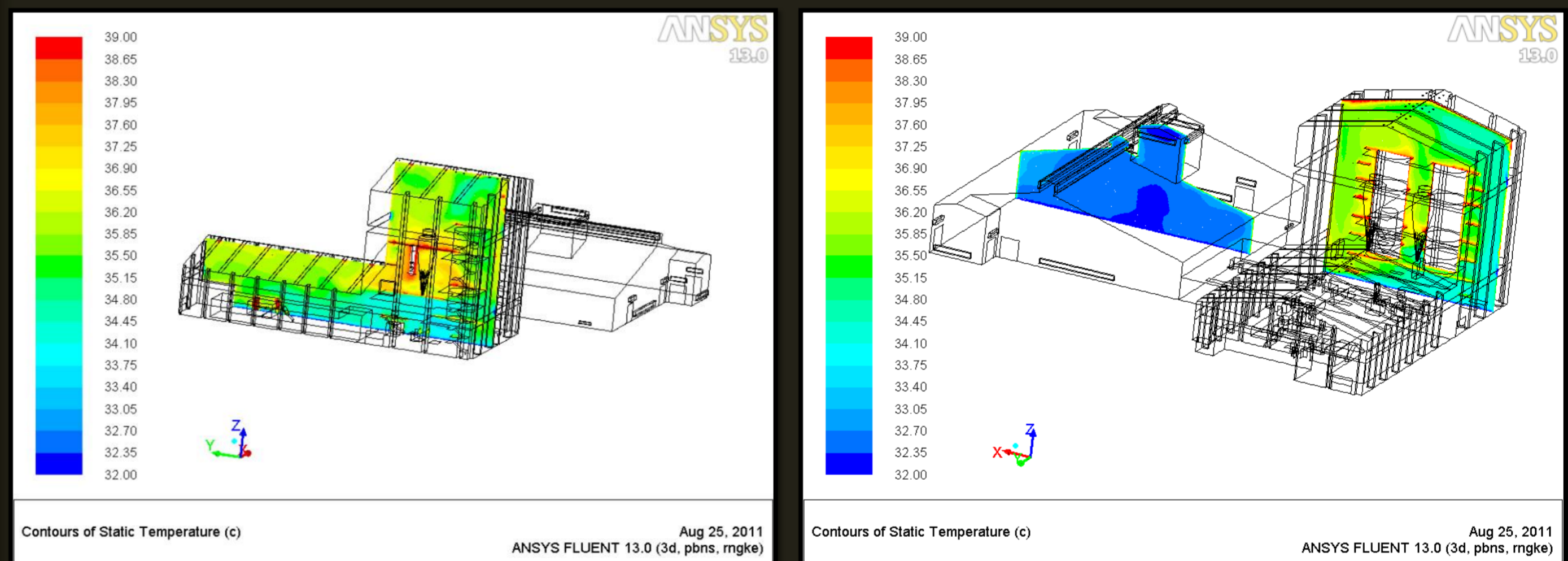

Fig. 2: Temperature Contour along Longitudinal Vertical Plane (Original Configuration)

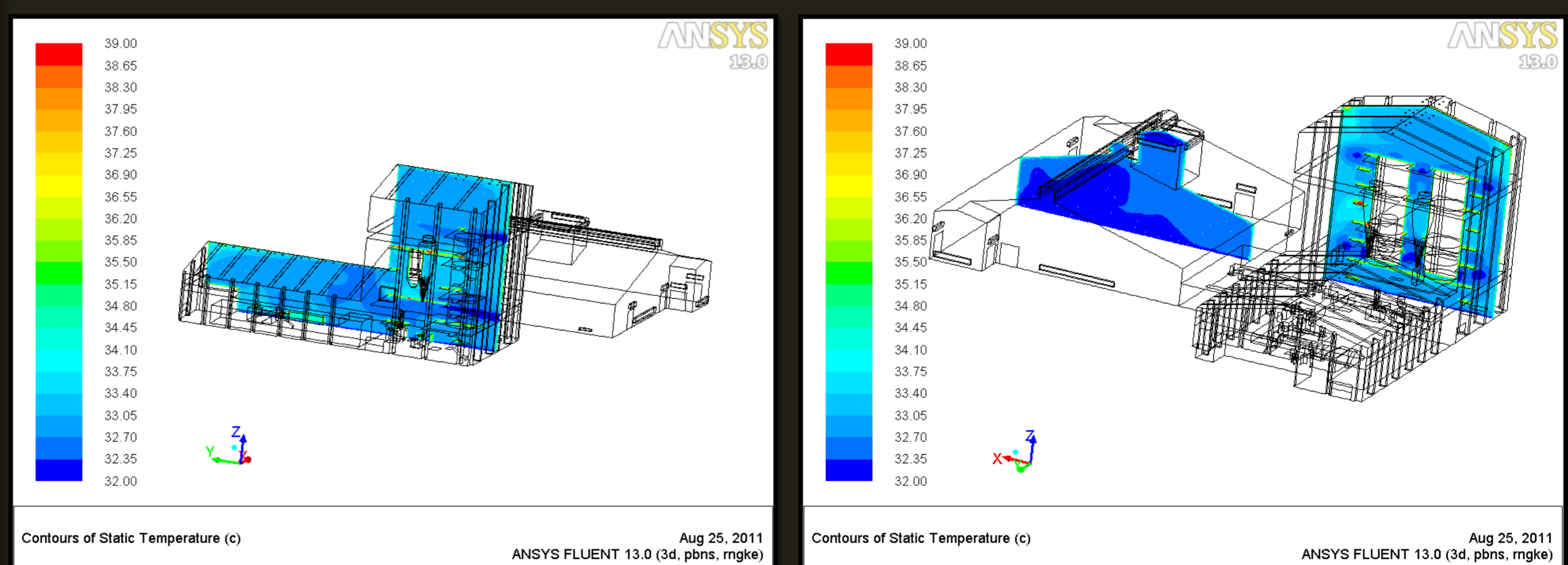

Fig. 3: Temperature Contour along Longitudinal Vertical Plane (Modified Configuration)